

Installation and User Guide for GSM6i/RF

English

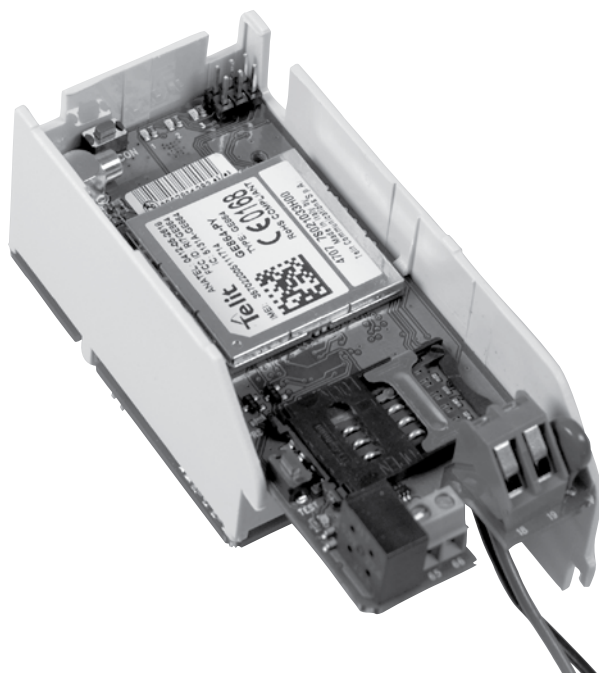

Kamstrup A/S
Industrivej 28, Stilling, 8660 Skanderborg
TEL: 89 93 10 00 · FAX: 89 93 10 01
info@kamstrup.com · www.kamstrup.com

Quick Guide

1. Make a signal test by activating the test button on the modem.
2. The signal strength must be at least 12.
3. The external antenna must be placed in a location that optimises the reception of the signal. Turn the external antenna around until the best position has been found. Run several signal tests while trying to find the best position.
4. You might use NetMonitor or a similar tool that can help to find the best position for the external antenna.
5. Before leaving the installation, test the signal strength by SMS. Make sure that all cabinets and doors are closed before sending the SMS.

Tips

- If the meter is mounted in a metal cabinet, the external antenna must always be placed outside the metal cabinet.
- Only use the Kamstrup Triangle Antenna as it is the only antenna to cover all RF and GSM frequencies in the same antenna.
- Note that fire doors, concrete and metal plates disturb and weaken the GSM signal.
- It is possible to order special directional antennas for areas with very poor signal conditions (please contact Kamstrup for further information).

Make sure to close all doors and cabinets before sending the SMS.

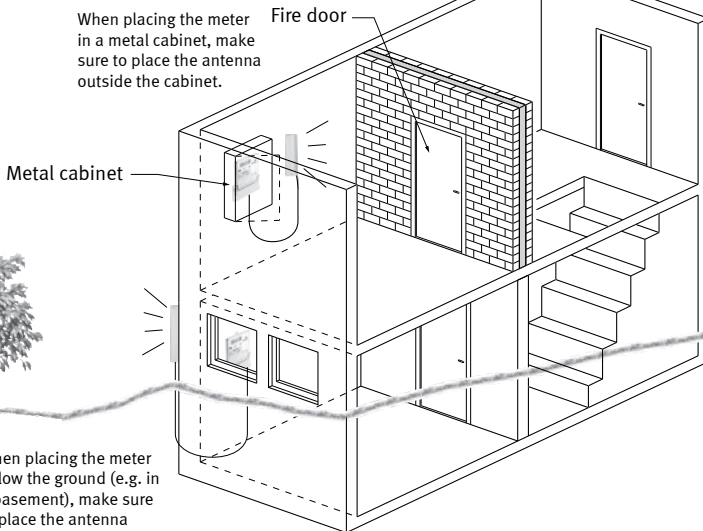

When placing the meter in a metal cabinet, make sure to place the antenna outside the cabinet.

Metal cabinet

Fire door

When placing the meter below the ground (e.g. in a basement), make sure to place the antenna close to a window or outside the building.

CONTENTS

1.	Description	5
1.1.	Description of GSM6i/RF.....	5
1.2.	Using GSM6i/RF.....	6
1.3.	Technical data	6
1.3.1.	<i>GSM6i/RF, article no. 6815-xxxx</i>	6
2.	Mounting	7
2.1.	Mounting order	7
2.2.	Start-up sequence.....	8
2.3.	Signal test	9
2.4.	Diagram for signal conversion	10
2.5.	Light-emitting diodes for GSM/GPRS.....	11
2.6.	SIM card.....	12
2.6.1.	<i>Mounting the SIM card</i>	12
2.6.2.	<i>SIM card requirements</i>	12
2.7.	Mounting the external antenna	13
2.7.1.	<i>Kamstrup 382 - type 685-282-zz-zz</i>	14
2.7.2.	<i>Kamstrup 382 - type 685-382-zz-zz</i>	15
2.7.3.	<i>Kamstrup 351 Combi - type 685-251-xx-xx-xxx</i>	16
2.7.4.	<i>Kamstrup 351 Combi - type 685-351-xx-xx-xxx</i>	17
2.8.	GPRS.....	18
2.9.	RF Concentrator	19
2.10.	Commissioning the RF Concentrator	19
2.11.	Connecting control relays	20
2.12.	Connecting status/pulse inputs	21
3.	Data in the GSM6i/RF Module, Article no. 6815-Dxxxx	22
3.1.	Data logger.....	22
3.2.	Backup	22
3.3.	Daily/weekly/monthly logger	23
3.4.	Load profile (minute logger)	24
3.5.	Event logger	24
4.	Tariff Shifting Function	25
5.	Error Detection Help	26
6.	SMS Commands	27
7.	GSM6i/RF Variant Structure	29

1. Description

1.1. Description of GSM6i/RF

GSM6i/RF, article number 6815-xxxxx, is a GSM/GPRS module with built-in RF Concentrator specially designed for mounting in Kamstrup electricity meters and in PLC Concentrators. The module will typically be used as a concentrator in an RF network. It is possible to configure the module as a data logger, including daily values, load profile, and event log.

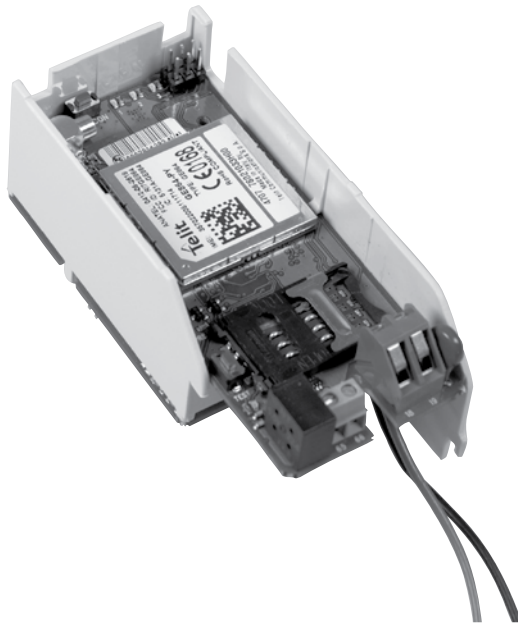

1.2. Using GSM6i/RF

The GSM6i/RF module is used in the following meters:

Article no.	Function	Meter types
6815-Txxxx	Transparent reading of meter or concentrator	Kamstrup 162 Kamstrup 382 Kamstrup 351 Combi PLC Concentrator
6815-Dxxxx	Communication with GSM6i/RF data logger (Data logger mode)	Kamstrup 162 Kamstrup 382 Kamstrup 351 Combi

1.3. Technical data

1.3.1. GSM6i/RF, article no. 6815-xxxxx

- Dual band GSM/GPRS module
- RF Concentrator for the 434 MHz or the 444 MHz frequency band
- To be mounted as a module in the electricity meter
- Data logger for load profile (5, 15, 30, 60 min.), daily/weekly/monthly logger and event logger
- Tariff and load control
- Central upload of new features, e.g. new tariff switch times
- Built-in real time clock (RTC) with minimum backup for 10 days
- RTC controlled GSM/GPRS reset
- Reading of electricity meters via SMS
- LED's for RF Concentrator status
- Status LED's for GSM/GPRS network and antenna signal
- GSM/GPRS signal indicator
- Control output for load control (230 VAC, max 100 mA)
- Status/pulse input

NOTE: Installation to be carried out by authorized personnel only as it can be highly dangerous to touch connections and internal parts.

2. Mounting

GSM6i/RF, article number 6815-xxxxx, is 230 VAC supplied and must be mounted with an external antenna. See also the variant structure at the end of the document.

2.1. Mounting order

1. Disconnect the voltage supply to the electricity meter.
2. Dismount the top cover of the meter.
3. Place the GSM6i/RF module in the meter (please check that the six module pins are all plugged in).
4. Insert SIM card (see paragraph 2.6).
5. Mount the 230 VAC supply mains as shown in paragraph 2.7.1 to 2.7.4 - please note the meter type. Be careful to lead the wires as shown on the drawings.
6. Mount the external antenna, *see paragraph 2.7*.
7. Connect the meter.
8. When the diodes on the GSM6i/RF module stop flashing, the signal strength is read on the indicator (see paragraph 2.3).
9. If the signal strength is acceptable, mount the top cover of the meter and make sure that the wires are not jammed.
10. Before leaving the installation, check the signal strength by SMS (see paragraph 6).

If the module does not indicate normal operation conditions (such as sufficient signal strength), see chapter 5 for error detection help.

NOTE: In meters delivered before 2004 it may be necessary to make room for the module by removing a bit of edge from the module area with a knife. Be careful not to leave any sharp edges, which can damage the wires.

2.2. Start-up sequence

1. Immediately after start-up, all the Signal indicator diodes and the test diode switch on briefly (see fig. 1).
2. The two Signal indicator diodes at the bottom flash until the module has been initialised correctly (approx. 5 secs.). When the diode at the bottom stops flashing, the module has been connected to the GSM network (approx. 5-10 secs.).
3. Now, the signal indicator will show the current signal level.
4. If the module is configured for communication via GPRS, the GPRS diode switches on as soon as the module is connected to the GPRS network (approx. 20 secs. after start-up).
5. All diodes will turn off after 10 min.

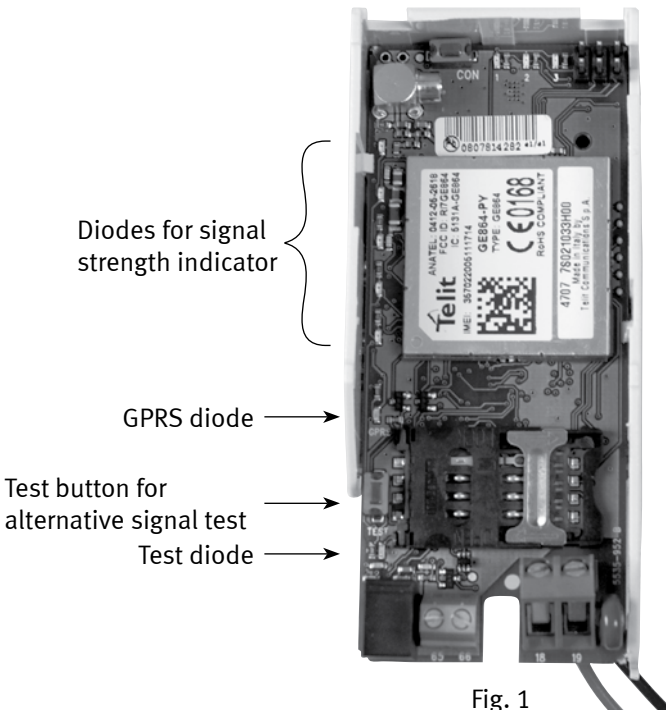

2.3. Signal test

Five LED's have been mounted on the GSM6i/RF module to indicate the current GSM signal strength.

Immediately after starting up the module, it will try to connect to the GSM network, and the signal strength indicator will be activated (see paragraph 2.2).

If a higher resolution of the signal strength is required, it is possible to make a signal test with the test button.

1. Activate the button for 2 secs. after which the test diode turns on and lights for approx. 10 secs.
2. The test diode will now indicate the signal strength with flashes.
One long flash equals 10 and a short flash equals 1.
E.g.: Two long flashes and three short flashes equal a signal strength of 23.
3. See paragraph 2.4 for more details.

2.4. Diagram for signal conversion

Signal indicated in dBm	Signal with button test	Signal indicator
-113	0	0
-111	1	0
-109	2	0
-107	3	0
-105	4	0
-103	5	0
-101	6	0
-99	7	0
-97	8	0
-95	9	1
-93	10	1
-91	11	1
-89	12	2
-87	13	2
-85	14	2
-83	15	3
-81	16	3
-79	17	3
-77	18	4
-75	19	4
-73	20	4
-71	21	5
-69	22	5
-67	23	5
-65	24	5
-63	25	5
-61	26	5
-59	27	5
-57	28	5
-55	29	5
-53	30	5
-51	31	5

GSM minimum

- *Note: At a signal strength below 12 we cannot guarantee a stable connection to the unit.*
- *The installation must not be handed over before the signal strength is 12 or more. An external antenna must always be mounted.*
- *The external antenna must be positioned in a place where it is not shielded, covered, or moved. Nor must it be mounted in closed metal cabinets.*
- *Only use the Kamstrup Triangle Antenna.*
- *Always complete the installation by sending an SMS (=signal#) to control the signal strength when all doors and cabinets are closed.*

2.5. Light-emitting diodes for GSM/GPRS

Signal Indicator (Green)	Indicates the current GSM/GPRS signal strength
LED's 1+2 flash	The module is starting up
LED 1 flashes	Is connecting to the GSM network
LED's 1 to 5 emit light	Indicates the current signal level
No LED's emit light	Poor GSM signal, mount an external antenna (note that all diodes turn off automatically after 10 min.)

GPRS (Orange)	Indicates the current GPRS status
LED emits light	The module is connected to the GPRS network

Test (Orange)	Is used for alternative signal test
LED emits light constantly	Emits light constantly for approx. 10 secs. during signal test
LED flashes constantly	The module cannot communicate with the electricity meter

**Note that all diodes will turn off after 10 min.
They can be reactivated by pushing down the test button for 2 secs.**

2.6. SIM card

2.6.1. Mounting the SIM card

The unit can be ordered with the SIM card mounted from the factory. Please check that the card has been inserted. The telephone number of the card appears from a label on the side of the GSM/GPRS module. The number can be read from the outside without dismounting the meter cover.

Kamstrup A/S cannot be held responsible for theft and misuse of SIM cards from GSM6i/RF units.

When the SIM card holder is opened, the supply to the SIM card is cut off. When the SIM card has been inserted correctly and the holder is closed, the module will restart automatically.

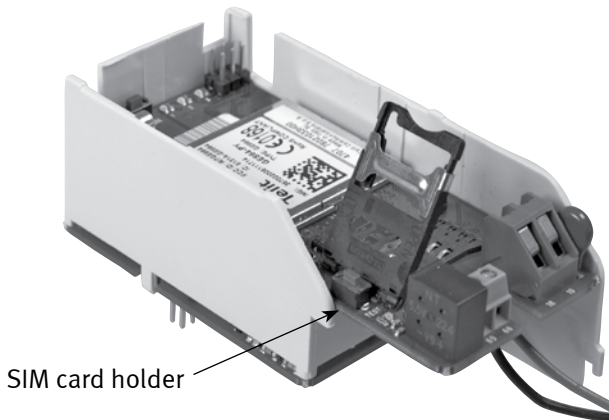

If the unit is supplied without a SIM card, make sure that it is inserted before using the unit.

The SIM card holder is opened by pushing the bright holder towards the left and carefully tipping up the holder. Place the SIM card with the “cut-off” corner in the top right side and with the contacts facing the print. Please remember to write the telephone number on a label placed on the outside of the unit.

2.6.2. SIM card requirements

The SIM card must fulfil the following requirements:

GSM/GPRS, DATA/SMS-9.6kb V110, PIN code must be disabled, no voice and no pre-paid card can be used.

2.7. Mounting the external antenna

Connect the external antenna to the connector on the module. Be careful to hear a “click” before the two connectors are connected correctly. Place the antenna cable inside the plastic frame of the module and lead it out, down through the cable channel at the bottom of the electricity meter. See picture below.

IMPORTANT

To ensure that the external antenna is mounted in a way that optimises the reception conditions, the signal indicator on the module must be followed (see paragraph 2.3). Turn the external antenna around until the best position has been found.

The external antenna is mounted



Do not mount the external antenna inside cabinets made of metal or other materials that disturb the signal

2.7.1. Kamstrup 382 - type 685-282-zz-zz

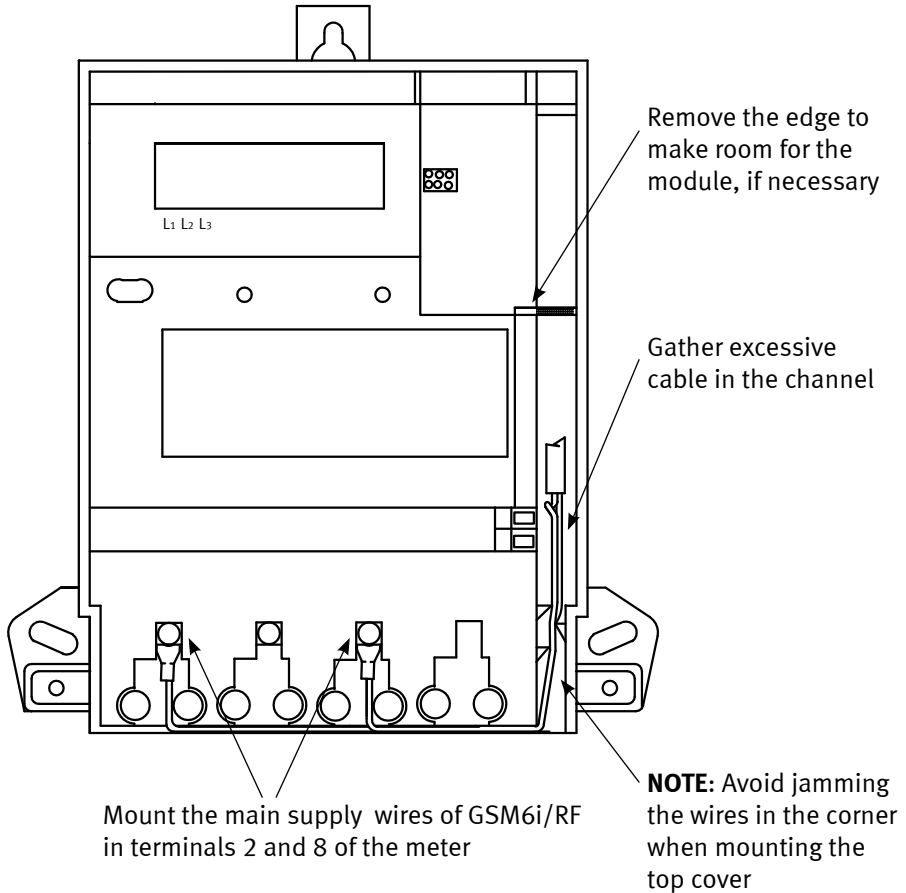

To gain access to the screw terminals, carefully tip up the main supply wires. After mounting, carefully put the supply wires back into the channel.

2.7.2. Kamstrup 382 - type 685-382-zz-zz

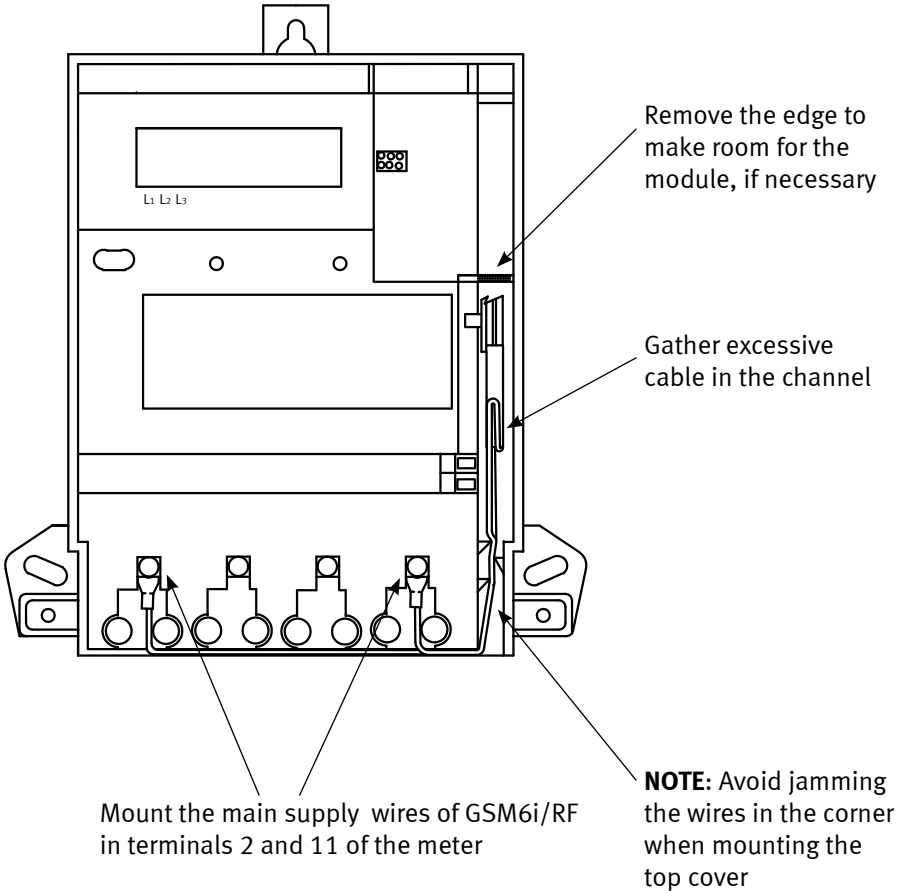

To gain access to the screw terminals, carefully tip up the main supply wires. After mounting, carefully put the supply wires back into the channel.

2.7.3. Kamstrup 351 Combi - type 685-251-xx-xx-xxx

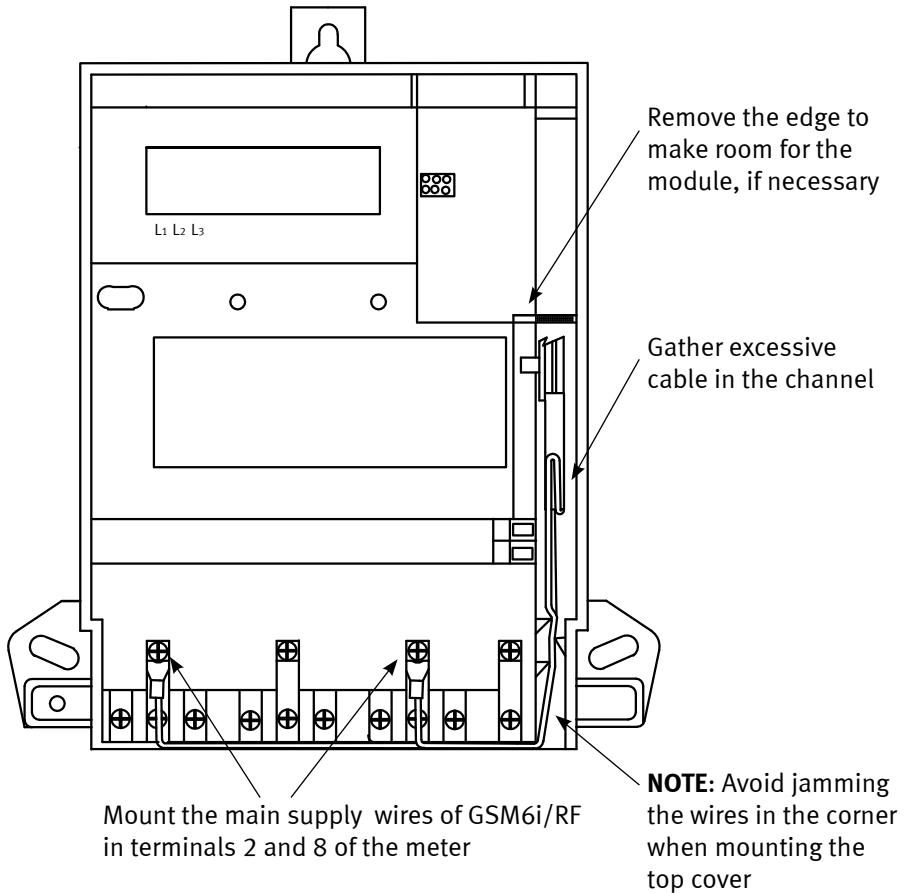

To gain access to the screw terminals, carefully tip up the main supply wires. After mounting, carefully put the supply wires back into the channel.

2.7.4. Kamstrup 351 Combi - type 685-351-xx-xx-xxx

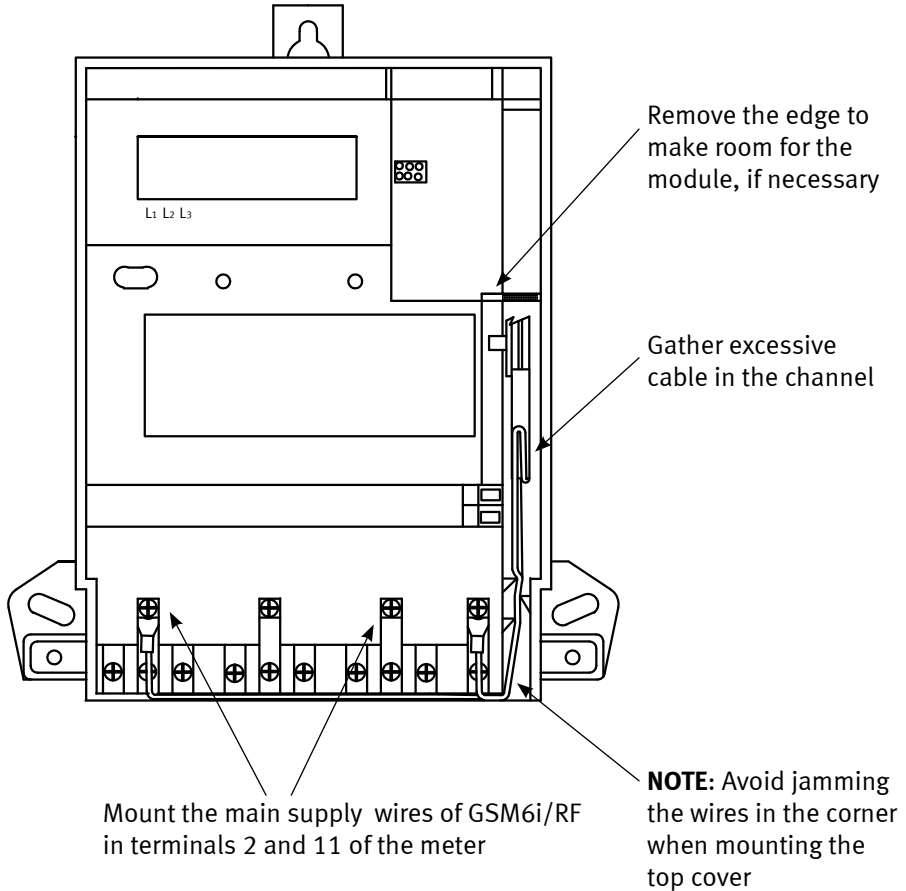

To gain access to the screw terminals, carefully tip up the main supply wires.
After mounting, carefully put the supply wires back into the channel.

2.8. GPRS

The Module supports both GSM and GPRS communication. It is possible to activate GPRS already when ordering, thus making it operational right away. Alternatively GPRS can be activated at a later stage (please contact Kamstrup for further information).

To communicate via GPRS some parameters must be determined prior to placing an order.

Set-up:

Kamstrup recommends that a closed APN (Access Point Name) is established with the telecommunications supplier which can only be reached via a VPN (Virtual Private Network). GSM6i/RF module has to use the APN name to log on to the APN via GPRS.

In short, following items must be cleared before placing orders:

- APN name (name of a closed user group)
- VPN connection (tunnel between a GPRS unit and reading system with data encryption)
- The network of the telecommunications supplier must be tested by Kamstrup
- Remember always to contact Kamstrup before placing GPRS orders

2.9. RF Concentrator

The RF Concentrator is the central network unit, which includes reading jobs and data for up to 680 radio/router modules.

2.10. Commissioning the RF Concentrator

Before commissioning please make sure that the module is mounted correctly, and that voltage is switched on.

On top of the GSM6i/RF module is a push button and three light-emitting diodes (LED) indicating in the form of flashing sequences the number of RF modules, RF Routers, and RF Concentrators that are within range of this RF Concentrator.

Press the push-button and release it when the first LED marked “1” is lit.

Release the push button. The RF Concentrator starts creating the local list.

When all LED’s are out, commissioning (i.e. update of the local lists) has been completed.

LED 1	Number of radio modules within range. One flash per RF module
LED 2	Number of radio/routers within range. One flash per radio/router
LED 3	Number of RF Concentrators within range. One flash per RF Concentrator

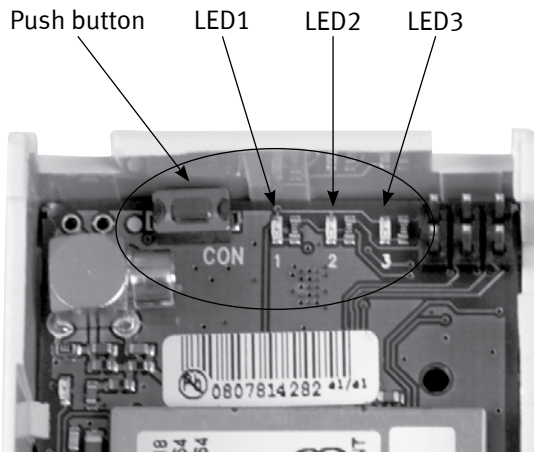

2.11. Connecting control relays

The control output is connected in series with the load. The control output must be loaded with a maximum of 230 VAC, 100 mA. An example of a connection between electricity meter and recommended relay (type G2RS, OMRON) is shown below.



Load control output
(max 230 VAC, 100 mA)

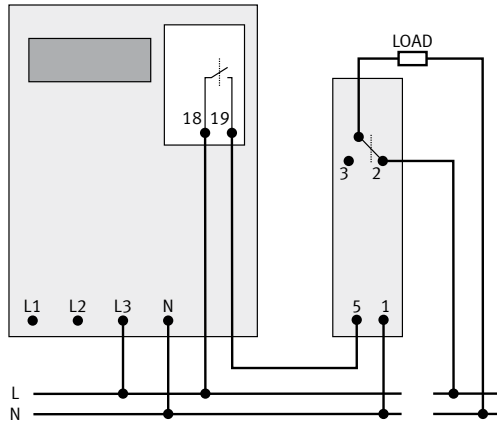

Example of a connection between electricity meter and relay, OMRON type G2RS switch relay

2.12. Connecting status/pulse inputs

The status/pulse input can be used to read the status of a potential-free contact or as pulse input from e.g. a water meter. If it is used as pulse input, the pulses will be counted in the pulse register of the electricity meter.

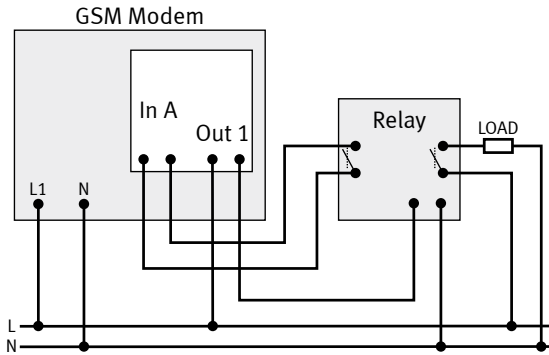

Load control output
(max 230 VAC, 100 mA)

3. Data in the GSM6i/RF Module, Article no. 6815-Dxxxx

3.1. Data logger

The data logger stores daily/weekly/monthly values, load profiles, and events.

All registers and data are reset when the module detects a new electricity meter (e.g. in connection with a new installation or replacement of the meter).

3.2. Backup

In case of power failure, the real time clock has a 10 days' backup, which means that the module is able to continue data logging once the power is re-established.

Logged data are stored in the EEPROM of the module, and are therefore not lost in connection with power failure.

NOTE: As a precaution, logged data will be deleted if the module is moved from one meter to another.

On the GSM6i/RF module itself, a 6-pole plug can be used for fall-back reading of the module's data logger in case of errors on the GSM network. Please contact Kamstrup A/S for further details.

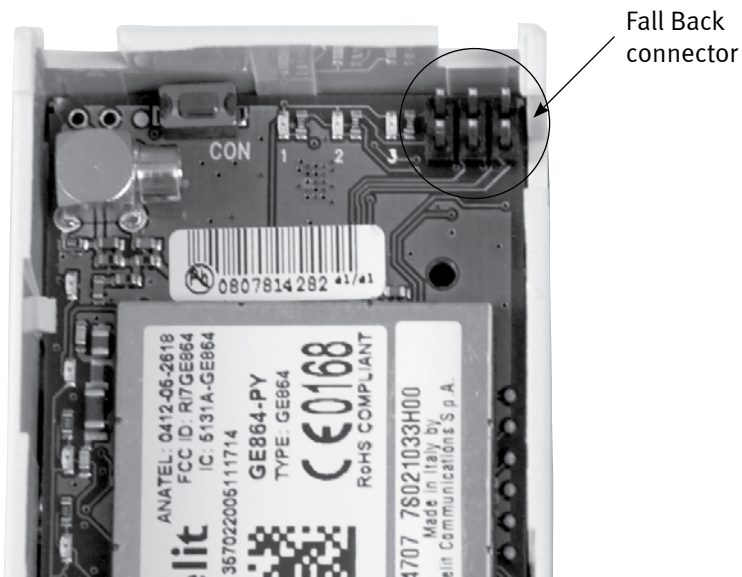

3.3. Daily/weekly/monthly logger

The daily/weekly/monthly logger consists of e.g. registers including tariffs and status information concerning the real time clock.

The daily logger stores values every day (at 00:00), on the night of Sunday and Monday (at 00:00) for the weekly logger, and for the monthly logger at the turn of the month (at 00:00).

The logging depth is 45 days, 45 weeks, and 45 months, respectively.

Please note that the daily, weekly, and monthly logger cannot be activated at the same time.

Register structure of the daily/weekly/monthly logger:

Time stamp	Register 1	Register 2	Register 3	Register 4	Kontrol
------------	------------	------------	------------	------------	---------

Time stamp				
Year	Month	Day	Hour	Minute

	Register 1	Register 2	Register 3	Register 4
Kamstrup 162	Actual energy, kWh	0	Tariff 1, kWh	Tariff 2, kWh
Kamstrup 382	Actual energy, kWh	0	Tariff 1, kWh	Tariff 2, kWh
Kamstrup 351 Combi	Actual energy, kWh	Actual energy, kvarh	Tariff 1, kWh	Tariff 2, kWh

Control							
Bit 0	Bit 1	Bit 2	Bit 3	Bit 4	Bit 5	Bit 6	Bit 7
Phase 1	Phase 2	Phase 3	Clock set	Clock adj. 7-15 secs.	Clock adj. 15-60 secs.	Clock not valid	Periodic error

3.4. Load profile (minute logger)

The load profile is composed of 5, 15, 30, or 60 minutes' values and the logging depth is 1080.

The logging depth for 60 minutes' values is 45 days.

The register structure for the load profile:

Time stamp	Register 1	Register 2	Control
------------	------------	------------	---------

Time stamp				
Year	Month	Day	Hour	Minute

	Register 1	Register 2
Kamstrup 162	Actual energy, kWh*	0
Kamstrup 382	Actual energy, kWh*	0
Kamstrup 351 Combi	Actual energy, kWh**	Actual energy, kvarh

Control							
Bit 0	Bit 1	Bit 2	Bit 3	Bit 4	Bit 5	Bit 6	Bit 7
Phase 1	Phase 2	Phase 3	Clock set	Clock adj. 7-15 secs.	Clock adj. 15-60 secs.	Clock not valid	Periodic error

*: The energy is registered with two decimals.

** : The energy is registered without decimals or as verified energy with two decimals.

3.5. Event logger

Among other things the event logger contains status information on the real time clock. The status information is stored with each change, e.g. time adjustment. The time adjustment is used for e.g. determining the duration of a voltage cut-off, two minutes being the minimum limit.

The logging depth is 64 events.

The register structure for the event logger:

Time stamp					Control
Year	Month	Day	Hour	Minute	

Control							
Bit 0	Bit 1	Bit 2	Bit 3	Bit 4	Bit 5	Bit 6	Bit 7
Phase 1	Phase 2	Phase 3	Clock set	Clock adj. 7-15 secs.	Clock adj. 15-60 secs.	Clock not valid	Periodic error

4. Tariff Shifting Function

The tariff shifting function allows two tariff shifts on weekdays and two tariff shifts during weekends as illustrated in the table below.

Furthermore, low tariff can be active on 30 optional days.

	Shift into T1	Shift into T2
Monday - Friday	1 shift/day	1 shift/day
Saturday - Sunday	1 shift/day	1 shift/day

It is possible to have two shifts within 60 min.

Example:

Definition tariff 2: 1. 1 January - 31 December, Monday - Friday 08:00-16:00

	Shift into T1	Shift into T2
Monday - Friday	16.00	8.00
Saturday - Sunday	T1 (no shift)	T1 (no shift)

5. Error Detection Help

NOTE: SMS commands must be sent in either capital or small letters.

Check that 230 VAC is available	
The test diode flashes.	The module has no contact with the meter. Check that it has been mounted correctly.
LED1 + LED2 at signal level the indicator flashes.	The module failed to connect to the GSM network. Check that the SIM card has been inserted correctly. Can also be caused by no GSM coverage.
The GPRS diode does not emit light after start-up.	Check that there is a GPRS subscription for the SIM card. Ask the telecommunications supplier.
Has the SIM card been inserted correctly?	See paragraph 2.6.1.
Is it the correct SIM card?	Check the telephone number and make sure that it is data subscription, see paragraph 2.6.2.
Weak GSM signal.	Try to improve the signal by placing the antenna in different places.
Try to call the unit.	A “modem/fax” sound can be heard provided there is no VOICE SIM card in the unit.
Send an SMS to the modem, e.g. = SIGNAL#	The unit must respond with the signal strength of the module.
Always make a final control reading from the main station.	Call the station and make sure that meter data have been received.
Defective modem.	Enclose a precise description of the error and return to Kamstrup.

6. SMS Commands

NOTE: SMS commands must be sent in either capital letters or small letters. Capital letters and small letters must not be mixed in the same SMS command.

READ_RTC - for reading the clock	
Syntax	=READ_RTC#
Example	=READ_RTC#
Return reply, correct. The clock will be read on Wednesday, 17 June 2007 at 13.11	13:11:27 17/06/07 3#
Return answer, error	NO ANSWER

READ_METER - for reading a direct electricity meter (Kamstrup 351, 382 or 162)	
Syntax	=READ_METER#
Example	=READ_METER#
Return answer, correct Meter no. 10101010 is read, the register is 32432 kWh, the power is 343 W, and the meter has operated for 2452 hours.	32432 kWh, 343 W, 2452 Hours, Meter no: 10101010
Return answer, error	NO ANSWER

SIGNAL - for reading the signal strength	
Syntax, command	=SIGNAL#
Example	=SIGNAL#
Return answer, correct Displays the current signal strength of the modem on a scale of 0 to 31 where 31 is best. The signal strength must be minimum 12	Signal: 16(0-31)
Return answer, error	NO ANSWER

CONTROL OUTPUT – for control of relay output

Syntax:	=CONTROL_OUTPUT <out1> <out2># (Note that there is only one relay output on this module <out1>)
Example Switch on relay 1 immediately	=CONTROL_OUTPUT 1 0#
Example Switch off relay 1 immediately	=CONTROL_OUTPUT 0 0#
Return answer, error	NO ANSWER

IOSTATUS for reading status of relay output and status/Pulse input

Syntax	=IOSTATUS# <i>(Note that there is only one relay output <relay1> and one input <input1> on this module)</i>
Example	=IOSTATUS#
Return answer, correct	Relay1: 1 Relay2: 0 Input1: 1 Input2: 0
Return answer, error	NO ANSWER

7. GSM6i/RF Variant Structure

681 –

<input type="checkbox"/>	<input type="checkbox"/>	<input type="checkbox"/>	<input type="checkbox"/>	<input type="checkbox"/>	<input type="checkbox"/>
--------------------------	--------------------------	--------------------------	--------------------------	--------------------------	--------------------------

GSM6i/RF

5

GSM Modul SW

Transparent T
 Data logger D
 Data logger verified..... V

Concentrator SW:

Concentrator RF module SW H

Features

None..... 0
 Earth fault 1

Country code

Other countries 00
 DK..... 10
 N..... 40
 S..... 90

Frequency:

EU..... 319
 Sweden 328
 Norway..... 339
 Denmark 349

Additional options:

SIM card

None	0
BillingCom SIM card - Danish	1
BillingCom SIM card - Swedish	2
SIM card supplied by the customer	3

Delivery

Module	1
Kit - Kamstrup 162 (module and top cover)	2
Kit - Kamstrup 382 (module and top cover 2002)	3
Kit - Kamstrup 351 Combi (module and top cover 2002)	4
Kit - Kamstrup 382 (module and top cover 2004)	5

Antenna

External antenna, (6699407)	1
External antenna, (6699408)	2

